

AGXV-540, AGXV-541, AGXV-542 & AGXV-543 AUTOMATIC SPRAY GUNS OPERATION MANUAL

DEVILBISS

**Important: Read and follow all instructions and SAFETY PRECAUTIONS before using this equipment.
Retain for future reference.**

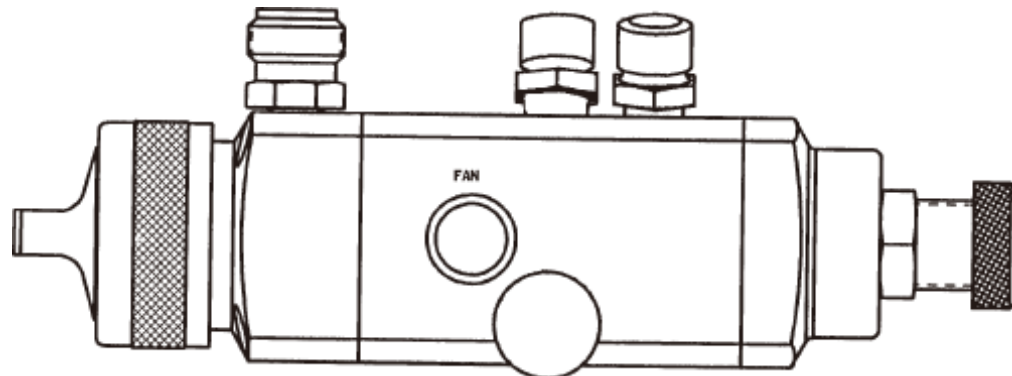

U.S. Patent No. 5,364,033

DESCRIPTION

The AGXV high volume, low pressure spray gun (spray pistol) is used on automatic and semi-automatic machines where mass production spraying is necessary, or hand spraying is not accurate enough. Models and application information follows. All models are designed to provide maximum transfer efficiency by limiting air cap pressure to 10 psi (0.7 bar) (in the U.S., this complies with rules issued by SCAQMD and other air quality authorities). Air cap pressure can be measured with an optional air cap test kit. See "ACCESSORIES" on Page 13.

Chart 1 MODELS

Model No. (Available Tip Sizes)	Typical Applications	HVLP Air Cap Used	Fluid Tip/Needle Construction
AGXV-540 (E, FF, FX)	Most common finishing materials including some waterborne and chlorinated.	33A	400 Gr. S/S 303 Gr. S/S
AGXV-541 (D, E, FF, FX)	High solids (low VOC's) coatings which are difficult to atomize with HVLP, or high flow rates.	46MP or 83MP	400 Gr. S/S 303 Gr. S/S
AGXV-542 (FF, FX)	Waterbornes and other corrosive materials (below 7pH)	33A	303 Gr. S/S, Poly.
AGXV-543 (FF, FX)	Same as AGXV- 541 except for more corrosive materials (below 7pH)	46MP	303 Gr. S/S, Poly.

Chart 2 AIR CAPS – PATTERNS – APPLICATION

Air Cap No.	Complete Air Cap No.	*Typical Pattern Size and Shape	Typical Application
33A	JGHV-101-33A	9" (229 mm) long, tapered ends, similar to 30 air cap.	Most common finishing materials, up to 12 oz./min. (360 cc)
46MP	JGHV-101-46MP	11" (280 mm) long, straight sided, similar to 704 air cap.	Low VOC materials, 12 to 16 oz./min. (360 to 480 cc)
83MP	JGHV-101-83MP	13" (330 mm) long, straight sided similar to 765 air cap.	Low VOC materials, 17 oz./min. (510 cc) and above.

* Actual pattern length dependent upon fluid tip (nozzle) ID, coating material flow rate, air pressure and fan pressure.

Most finishing materials can be atomized with the 33A air cap. The 33A cap should be used where possible as it consumes less air volume (CFM) and has slightly better transfer efficiency than the 46 MP or 83MP air caps. However, more difficult to atomize materials (i.e. low VOC's) or high flow applications over 12 oz./min. (360 cc/ min.), are ideal for the 46 MP maximum performer air cap, fluid tip and baffle combination. Also available is the 83MP (maximum performer) for even higher flows 17 oz./min. (510 cc/min.) and above and higher viscosities. Refer to the air cap chart for more information.

Note

This gun may be used with chlorinated solvents. Aluminum is not used in fluid passages. If using chlorinated solvents, make sure all other fluid handling components are also compatible.

A list of materials used in the construction of this equipment is available upon request.

SPECIFICATIONS

P1 – Maximum Inlet Pressure	0.69MPa (100 psi)
P2 – Maximum Fluid Pressure	0.69MPa (100 psi)
P3 – Cylinder Air Pressure	Min. 0.35MPa (*50 psi) Max. 0.69MPa (100 psi)
Weight	without mounting stud 738g with mounting stud 865g
Mounting Stud Diameter	3/4" (19 mm)
Wetted Parts	300 and 400 S/S, PTFE, Poly. (See Chart 2 for tip/needle information)
Hose Connections	- Fluid Inlet 3/8" NPS(M) - Cylinder Air 1/4" NPS(M) - Atomization Air 1/4" NPS(M)

Note

For HVLP operation (max. 10 psi, - 0.7 bar cap pressure), do not exceed the air inlet pressure given below.

MPa (psi)	Cap No.
0.39(57)	83MP
0.35(50)	46MP
0.31(45)	33A

* For installations where 0.35MPa (50psi) cylinder air is not available, the inner (red) piston spring can be removed which lowers the minimum cylinder air to approximately 0.26MPa (37psi). Refer to "OPERATION", Pg. 4

FLUID TIP (NOZZLE) ORIFICE SIZES

	Inch	mm
D	0.086"	2.2
E	0.070"	1.8
FF	0.055"	1.4
FX	0.042"	1.1
G	0.028"	0.7



PROP 65 WARNING

WARNING: This product contains chemicals known to the State of California to cause cancer and birth defects or other reproductive harm.

SAFETY PRECAUTIONS



This manual contains important information that ALL users should know and understand BEFORE using this equipment. This information relates to USER SAFETY and PREVENTING EQUIPMENT PROBLEMS.

To help you recognize this information, we use the following terms to draw your attention to certain equipment labels and portions of this manual. Pay special attention to any label or information that is highlighted by one of these terms:

WARNING	Important information to alert you to a situation that might cause serious injury or loss of life if instructions are not followed.
CAUTION	Important information that tells how to prevent damage to equipment.
NOTE	Information that you should pay special attention to.

WARNING

The following hazards may occur during the normal use of this equipment. Please read the following chart.

HAZARD	CAUSE	SAFEGUARDS
Fire 	Solvents and coatings can be highly flammable or combustible, especially when sprayed.	<ol style="list-style-type: none"> 1. Adequate exhaust must be provided to keep the air free of accumulations of flammable vapors. 2. Smoking must never be allowed in the spray area. 3. Fire extinguishing equipment must be present in the spray area. 4. Static discharges must be prevented. Ground (earth) all conductive objects in the spray area, such as a cleaning solvent bucket, fire extinguisher, etc. 5. When using solvents for cleaning: <ul style="list-style-type: none"> · Those used for equipment flushing must have a flash point equal to or greater than that of the coating. · Those used for general cleaning must have flash points above 100°F (37.8°C).
Inhaling Toxic Substances 	Certain materials may be harmful if inhaled or if there is contact with the skin.	<ol style="list-style-type: none"> 1. Follow the requirements of the Material Safety Data Sheet supplied by coating material manufacturer. 2. Adequate exhaust must be provided to keep the air free of accumulations of toxic materials. 3. Use a mask or respirator whenever there is a chance of inhaling sprayed materials. The mask must be compatible with the material being sprayed and its concentration. Equipment must be as prescribed by an industrial hygienist or safety expert, and be NIOSH approved.
Explosion Hazard – Incompatible Materials 	Halogenated hydrocarbon Solvents- for example: methylene chloride and 1,1,1,-Trichloroethane are not chemically compatible with the aluminum that might be used in many system components. The chemical reaction caused by these solvents reacting with aluminum can become violent and lead to an equipment explosion.	The AGXV spray gun can be used with these solvents. However, aluminum is widely used in other spray application equipment – such as material pumps, cups, regulators, valves, etc. Check all other equipment items before use of these solvents. Read the label or data sheet for the material you intend to spray. If in doubt as to where or not a coating or cleaning material is compatible, contact your material supplier.

HAZARD	CAUSE	SAFEGUARDS
General Safety	Improper operation or maintenance may create a hazard.	Operators should be given adequate training in the safe use and maintenance of the equipment (in accordance with the requirements of NFPA-33, Chapter 15 in U.S.). Users must comply with all local and national codes of practice and insurance company requirements governing ventilation, fire precautions, operation, maintenance and housekeeping (in the U.S., these are OSHA Sections 1910.94 and 1910.107 and NFPA-33).
Noise Levels – Ear Injury 	A continuous A-weighted sound pressure level of this spray gun (spray pistol) may exceed 85 dB(A) depending on the air cap/ fluid head setup being used. Sound levels are measured using an impulse sound level meter and analyzer, when the gun is being used in a normal spraying application.	Always wear ear protection when using the gun. Details of actual noise levels produced by the various air cap / fluid head setups are available upon request.
Spraying solvent 	During cleaning and flushing, solvents can be forcefully expelled from fluid and air passages. Some solvents can cause eye injury.	Wear eye protection.
<p>Misuse:</p> <ul style="list-style-type: none"> · All spray guns project particles at high velocity and must never be aimed t any part of body. · Never exceed the recommended safe working pressure for any of the equipment used. · The fitting of non-recommended or non-original accessories or spare parts may create hazardous conditions. · Before dismantling the equipment for cleaning or maintenance, all pressures, air and material, must be isolated and released. <p>The disposal of waste materials must be carried out in an approved manner. Burning may generate toxic fumes. The removal or waste solvents and coating materials should be carried out by an authorized local waste disposal service.</p>		

FIGURE 1 DIMENSIONS



INSTALLATION

Mount the gun with the stud (13) or on a 5/16" dia. rod tightening adequately with the 1/4-28 X 1/4" set screws (Ref. No. 24). See "ACCESSORIES" for mounting clamps.

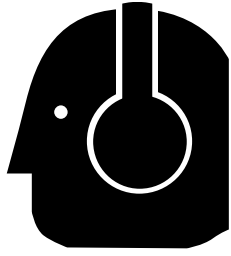
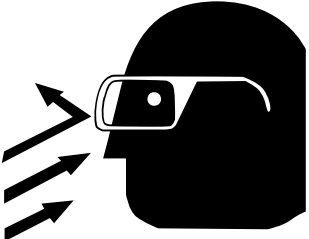
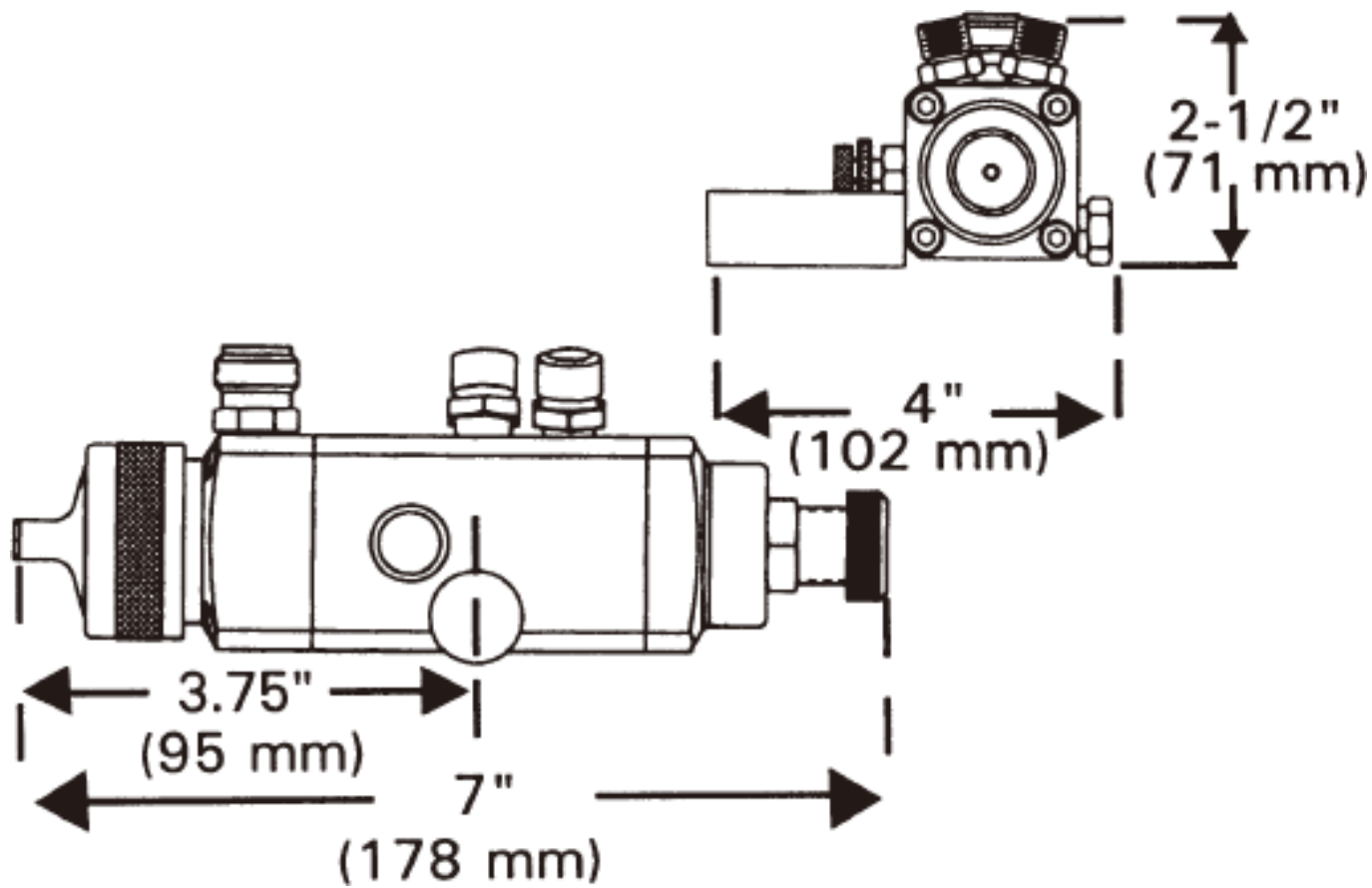
Note

If replacing the atomization air connection (15) with an elbow type connection, be aware of a possible air flow (CFM) limitation. A 1/4" (6.4 mm) I.D. 90° elbow will only pass 20 CFM @ 0.28MPa (40 psi) (566ℓ/min 2.7 bar). Some air caps require more than 20 CFM (566ℓ/min). Spray performance could be affected.

Figure 2. TYPICAL INSTALLATION

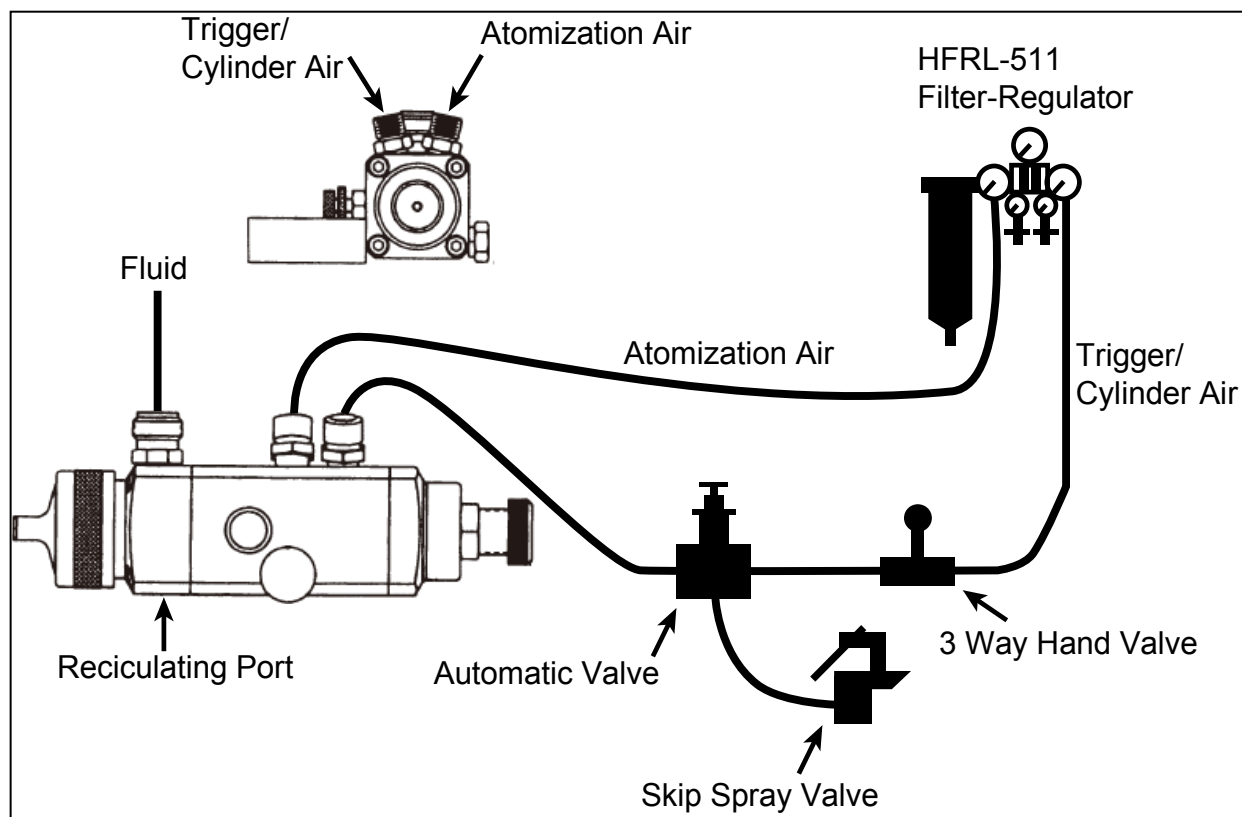

Attach trigger/cylinder air hose and atomization air hose to connections as indicated by markings on gun body. The air supply should be filtered and regulated. Attach material hose to fluid inlet on the body. Fluid can be recirculated by installing a fluid fitting (AGX-415) (order separately) at recirculating port. See Caution below.

CAUTION

The fluid inlet and recirculating ports have a tapered seating surface intended for use with the AGX-415 fitting. Do not substitute other fittings as fluid leakage will occur.

Note

If replacing the atomization air connection (15) with an elbow type connection, be aware of a possible air flow (CFM) limitation. A 1/4" I.D. 90° elbow will only pass 20 CFM @ 0.28MPa. Some air caps require more than 20 CFM. Spray performance could be affected.

OPERATION

1. Mix, prepare and strain material to be sprayed according to paint manufacturer's instructions. Use a lint free mesh to strain material.
2. Turn on cylinder air at source of supply. Supply air should be a minimum of 0.35MPa (3.5 bar). For consistent operation the pressure should be regulated. If 0.35MPa cylinder air pressure is not available, the red inner spring (31) can be removed. This allows a minimum cylinder pressure of approximately 0.26MPa.

Note
If red inner spring (31) is removed, atomization pressure should not exceed 0.48MPa (will result in gun not shutting off).

3. Turn needle adjustment knob (25) counterclockwise several turns. With the cylinder air on, turn the adjustment knob (25) clockwise until it contacts piston (19) (for maximum fluid flow). Back knob out 1/2 turn.

Note
Due to close part tolerances, actuate gun on and off 7 or 8 times to "break-in" the packings. Do this with material supply off.

4. Adjust atomization air pressure to 0.35MPa (3.5 bar) or less. Always attempt to keep pressure as low as possible to minimize overspray. The fluid pressure should be between 0.07MPa to 0.1MPa (0.7 to 1.0 bar).
5. Open hand valve and/or trip automatic valve if installed in system and observe spray pattern. Adjust air and fluid pressures until desired pattern is obtained. Control fluid pressure at source of supply. If desired regulation is not practical at this point, restrict flow by turning adjustment knob (25) clockwise.

Back Pressure – 46MP and 83MP "Maximum Performer"

Due to the unique cone shape of the MP fluid tips (nozzle), a slight back pressure is created against the fluid column. This will reduce the amount of fluid output. To compensate, increase the fluid regulator pressure slightly if necessary. With 0.07MPa (0.7 bar) cap pressure, back pressures are approximately 0.02MPa (0.24 bar) with the 46MP and 0.01MPa (0.14 bar) with the 83MP.

6. The width of the spray pattern is controlled by the adjusting valve (23) marked "FAN". With the "FAN" valve screwed fully clockwise, the spreader air will be closed off causing a round pattern. By gradually opening this valve, the pattern changes to a fan spray. The width is determined by the amount the valve is opened. Atomization air is adjusted by regulating the supply air to the gun.

Adjustments to fan may be controlled remotely by using the optional KK-4955 fan control adapter to replace the AGG-403 control valve (23). A separate solenoid valve is required to control on/off function. See Figure 2A.

7. Close the automatic valves and begin operation.

Figure 2A. AIR CIRCUIT EXAMPLE WITH OPTIONAL KK-4955 REMOTE FAN CONTROL

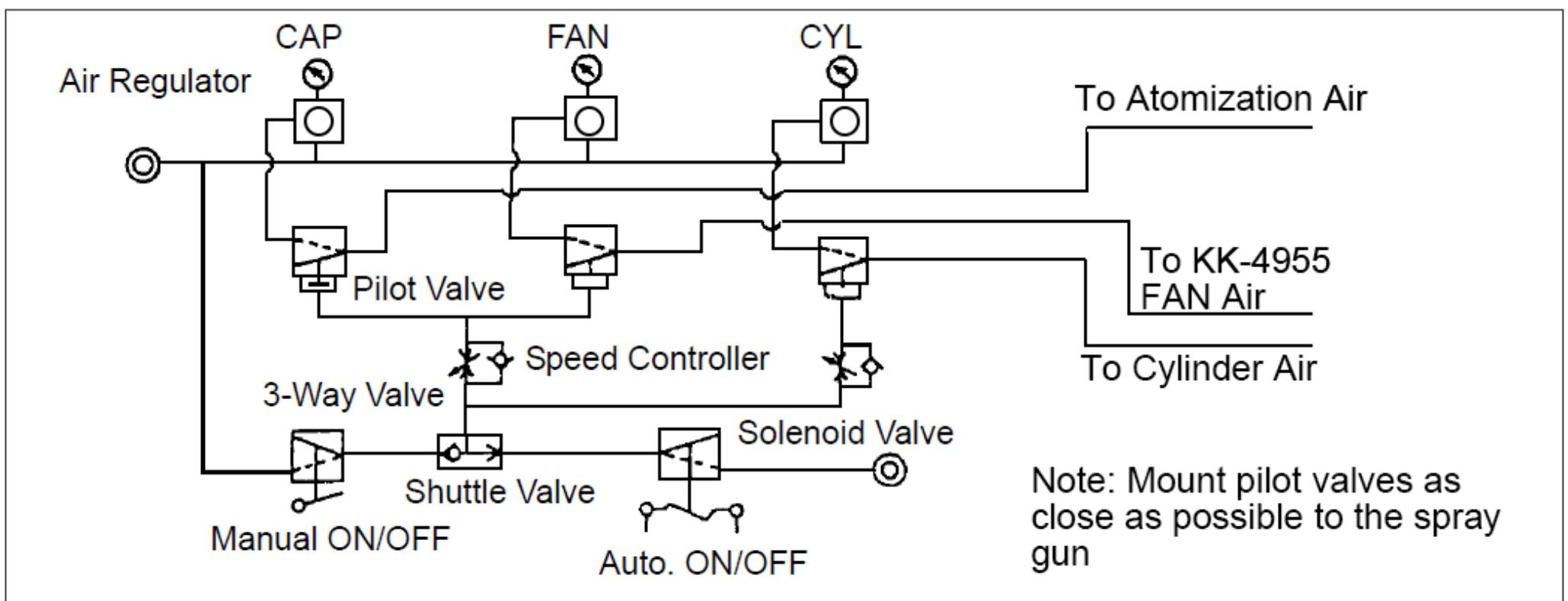

CHART 3 FLUID TIPS (NOZZLE) AND NEEDLES

Tip Size		Tip No.		Needle No.
400 Gr. Stainless Steel Tip/303 Stainless Steel Needle				
	In	mm		
E	.070"	1.8	AV-2115-E	AGX-402-E
FF	.055"	1.4	AV-2115-FF	AGX-402-FF
FX	.042"	1.1	AV-2115-FX	AGX-402-FX
G	.028"	0.8	AV-2115-G	AGX-402-G
FF	.055"	1.4	AV-2120-FF	AGX-402-FF
FX	.042"	1.1	AV-2120-FX	AGX-402-FX
D	.086"	2.2	AV-2120-D**	AGX-402-D
E	.070"	1.8	AV-2120-E**	AGX-402-E

* For use with 46MP air cap.

** For use with 83MP air cap.

PREVENTIVE MAINTENANCE

WARNING

Risk of Injury. Equipment and fluid may be under pressure.

Pressure in the system must be relieved before beginning the cleaning procedure and before replacing any parts. Follow the procedures in the service literature provided with the system.

CLEANING

1. Relieve air pressure from pressure tank. Carefully follow instructions in the service bulletin sent with tank.
2. Replace material in container with a suitable solvent.
3. Re-pressurize system.
4. Trigger the gun and repeat the procedure until the gun and hose are thoroughly clean (solvent is clean when it looks the same as when you first opened solvent container). A SolventSaver™ type hose and gun cleaner which supplies a mixture of air and solvent can be used to most effectively clean the gun and hose internal passages. See "Accessories" on page 13. Wipe the exterior of the gun with a solvent dampened cloth.
5. If a recirculating system is used, it may be necessary to fit a shut off valve in the return line to ensure the fluid tip and forward portion of the sprayhead passage are properly cleaned when flushed with solvent.

CAUTION

Do not totally submerge the gun in solvent. It is possible to wash solids into the air operating sections of the gun which could damage piston "O" ring seals.

CAUTION

The air cap can be immersed in solvent for cleaning. If the orifices are clogged, use a broom straw or toothpick to remove the obstruction. Never use a steel wire or hard instrument. This will damage the air cap and result in a distorted spray pattern.

REPLACEMENT

PARTS REPLACEMENT

Adjustable Wrench or "C" Spanner
1/2" Box Wrench or 1/2" Socket Spanner (Ref. 3)
9/16" Open Wrench (Ref. 9) or 9/16" spanner
Long Neck Pliers (19) or long nose grips
Hex Wrench 1/8" for (Ref. 24)
Hex Wrench 3/16" for (Ref. 7)
Torque wrench (in.-lbs. and ft.-lbs.)
1/2" and 9/16" sockets

Fluid needle (28) , Tip (3) and Needle Packings (11)

1. Relieve all air and fluid pressure in the system.
2. Remove retaining ring (1) & air cap (2).
3. Remove fluid tip (3).

CAUTION

To avoid serious gun damage, do not remove the fluid tip (nozzle) (3) from the spray gun (spray piston) when the fluid inlet adapter (6 or 9) is removed. Doing so may allow the stainless steel insert to break free from the aluminum body, which is non-repairable.

4. It is recommended that both the fluid tip (nozzle) (3) and the needle (28) be replaced at the same time. The needle packings (11) should also be replaced when replacing the needle.
5. Remove adjusting knob (25).
6. Remove needle (28) with pliers.
7. Loosen four screws (7) and remove sprayhead (8).
8. With the sprayhead (8) removed, the packings (11) can be easily removed and replaced.
9. Slide onto the new needle (28), in this order, 1 packing (11), spring (12) and 1 packing (11). Be sure to orient the packings as shown (Figure 4).
10. Assemble sprayhead (8) with retaining screws (7).
11. Tighten screws (7) with a 3/16 hexagon key 30-40 in. lbs. (3.4 - 4.5 N-m) until the body is flush with sprayhead assembly.
12. Reassemble in reverse order.

Piston (19) , O-Rings (17 & 18) and Air Packing (20)

1. Remove the piston housing (29) by removing rear retaining screws (7).
2. Remove fluid needle (28).
3. Remove springs (30, 31 & 27) and piston (19). Care must be taken when removing the piston (19). Use a locking long nose pliers to extract the piston by clamping on the inner ring on the back of the piston.
4. Remove the air packing (20), "O" rings (17 & 18).
5. Wipe clean the bore of the cylinder. Replace the piston "O" rings (17 & 18) and lightly lubricate with clean petroleum jelly. See "LUBRICATION" section which follows.
6. To replace air packing (20) (inside of the piston), slide packing (20) over the needle (28) with the lead-in chamfer towards the fluid tip (nozzle) end of the needle. Insert the needle into the piston (19). Hold the piston in your hand so that the tip end of the needle is protruding downward (protect the needle from damage). Lightly tap the blunt end of the needle to drive the packing down into the piston. The needle will stop inside the piston at a shoulder.
7. Fit complete assembly into gun.
8. Lubricate the outside of springs (31) and (27) (see "LUBRICATION" section), then re-install springs and piston housing (29) and tighten down and torque mounting screws (7) 30-40 in. lbs. (3.4 to 4.5 N-m).
9. Lubricate the adjustment knob threads (25) after cleaning with ·SSL-10 Gun Lube. Loosen the locking nut (26) before screwing the adjustment knob in.

Material Safety Data Sheet available from DeVilbiss upon request.

Plug (6) or Fluid Insert (9)

WARNING

Halogenated Hydrocarbon solvents can chemically react with aluminum. A risk of explosion or severe corrosion will occur. The following assembly step must be carefully performed.

If replacing AGX-415 inlet fitting, or if it should loosen, follow the assembly procedures below, and refer to Figure 3.

1. If installing a used fitting, clean paint and thread sealant from the fitting threads and gun body.
2. Screw the jam nut all the way onto the fitting. Then apply a medium strength thread sealant (i.e. Loctite 242 blue, or equal) to the first few threads of the fitting.
3. Install the AGX-415 fitting into the spray gun and tighten to a maximum of 12 ft. lbs. (16.3 N-m) torque. (Do not overtighten, damage may occur.)
4. Tighten the jam nut to 16 ft. lbs. (21.7 N-m) torque using a thin 9/16" open end wrench.
5. Use two adjustable wrenches when removing a hose connection from AGX-415 to prevent the inlet fitting from loosening.

Figure 3

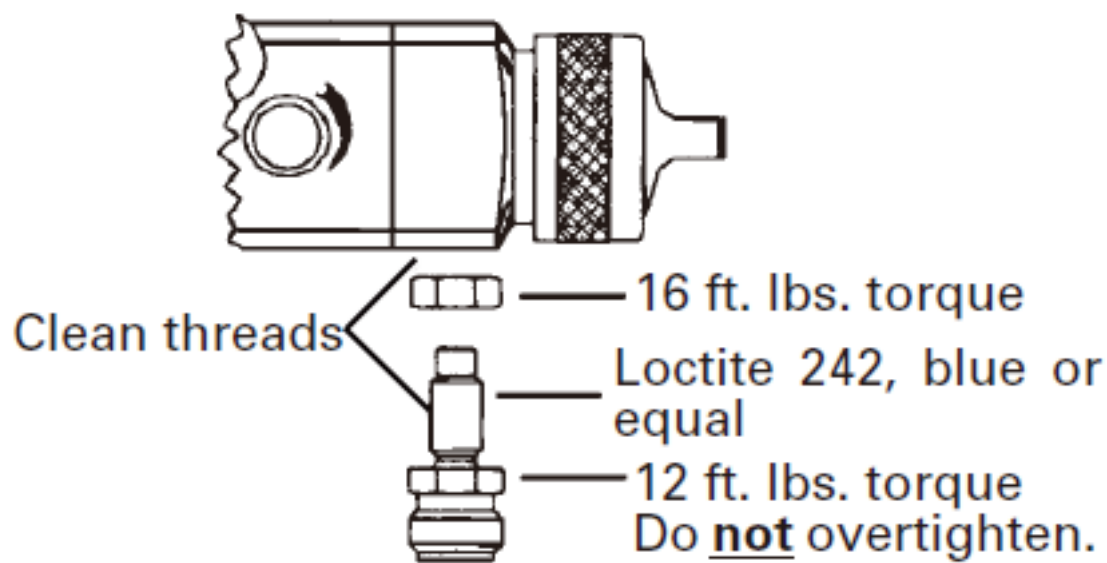

LUBRICATION

The piston O-rings (17 and 18) must be lubricated when the piston (19) is removed. Lightly lubricate with clean petroleum jelly. Do not use silicone-based lubricants. Petroleum jelly is effective as a lubricant up to approximately 110°F (43°C). Above 110°F (43°C), petroleum jelly will become "liquid" and will not lubricate the O-rings adequately. If the ambient temperature adjacent to the spray gun exceeds 110°F (43°C), use Parker O-Lube or suitable high temperature grease. This allows the spray gun to be used in temperatures up to 150°F (65° C) continuous without lubrication degradation.

Lubricate the outside of the larger piston spring (30) and needle spring (27) with a light coating of non-silicone grease. Apply a thin film of petroleum jelly (petroleum based grease) to the fluid needle (28) as shown in the "Note" on Page 10.

Note

Due to close part tolerances, after repairing the gun, actuate the gun on and off 7 or 8 times to "break-in" the air packing (20). Do this with the material supply off.

Figure 4 GUN ASSEMBLY

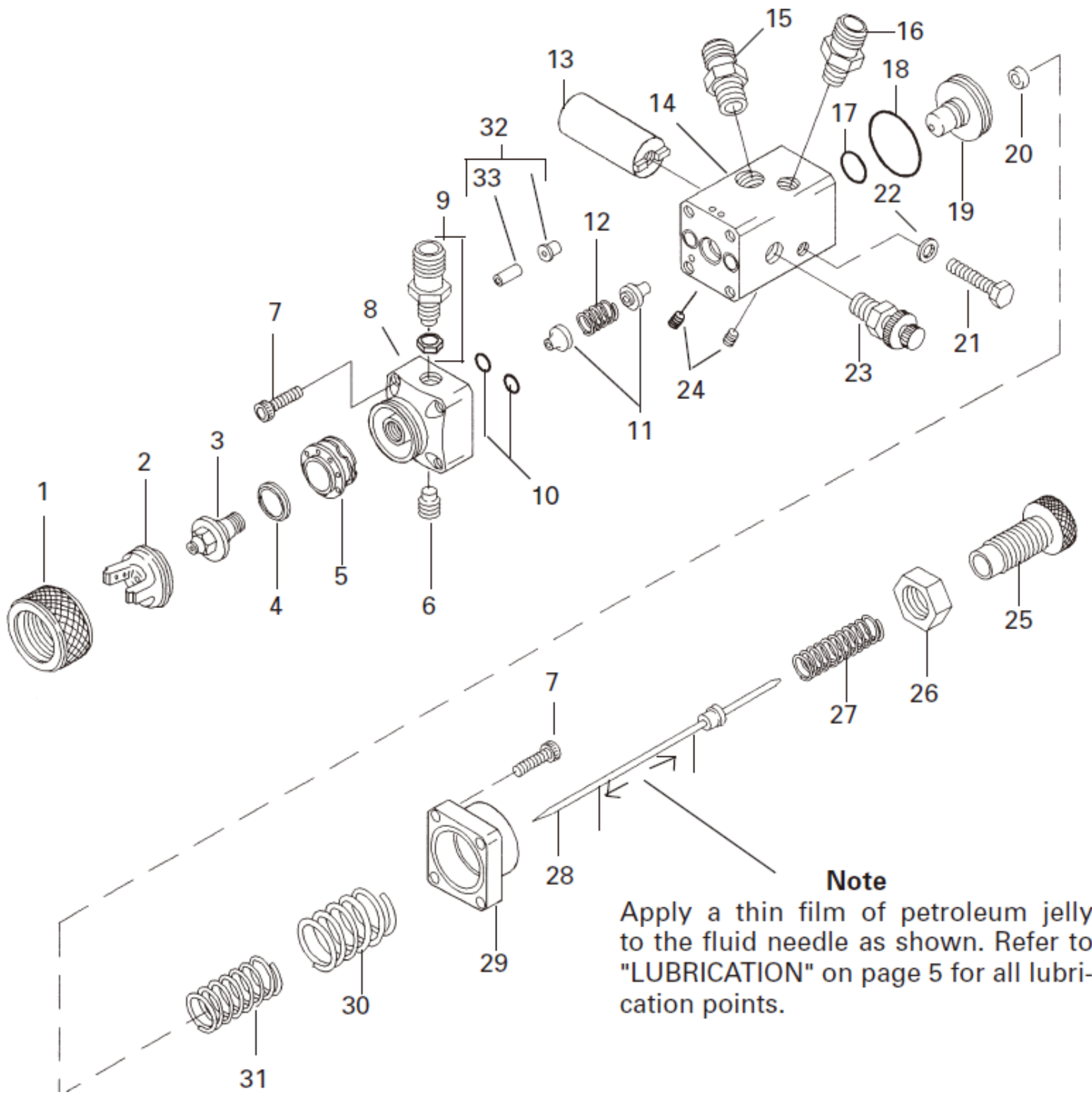

Item No.	Replacement Part No.	Description	Ind. Parts Req' d.
1	MBC-368 MSA-1	Retaining Ring (plated brass) Retaining Ring (Delrin) (Optional)	1
2*	See Chart 2	Air Cap	1
3*☆	See Chart 3	Fluid Tip (nozzle)	1
4*▲	AV-1-K5	Gasket	1
5	AGHV-403	Baffle	1
6	AGX-6-K3	Fluid Outlet Plug (Kit of 3)	1
7	SSF-3156-K4	Mounting Screw (Kit of 4)	8
8	AGX-403	Sprayhead Assembly	1
9	AGX-415	Inlet Fitting and Jam Nut	1
10*▲	---	"O" Ring, Buna-N	2
11*▲	---	Needle Packing, PTFE	2
12*▲	---	Seal Spring	1
13	KK-4995	Gun Mounting Stud Kit (Includes items 13, 21, 22 & 24)	1
14	AGX-11	Body	1
15	H-2008	Nipple 1/4 NPS(M) x 1/4 NPT(M)	1
16	H-1766	Nipple 1/4 NPS(M) x 1/8 NPT(M)	1
17*▲	---	O-Ring	1
18*▲	---	O-Ring	1
19	AGX-9	Piston	1

Item No.	Replacement Part No.	Description	Ind. Parts Req' d.
20* [▲]	---	Air Packing	1
21	---	Hex Head Cap Screw, 5/16-18 x 2-1/4	1
22	---	5/16 Lockwasher	1
23	AGG-403	Air Valve Assembly - Horn	1
24	---	1/4-28 x 1/4" Large Knurled cup point set screw	2
25	AGX-2-1-K3	Adjustment Knob (Kit of 3)	1
26	34215-122	Locknut	1
27* [■]	---	Needle Spring	1
28* [☆]	See Chart 3	Fluid Needle Assembly	1
29	AGX-10	Piston Housing	1
30* [■]	---	Outer Piston Spring	1
31* [■]	---	Inner Piston Spring (Red)	1
32*	KK-5017	Abrasive Fluid Seal Kit (optional, includes 3 seals and 1 brass collar)	1
33 [▲]		Abrasive Fluid Seal (U.H.M.W. Poly.)	1

* Recommended spare parts.

[▲] Parts included in KK-4992-1 Gun Repair Kit.

[☆] Order set, See Chart 2.

[■] Springs included in KK-4993 Spring Kit.

Detail Ref. No. 32

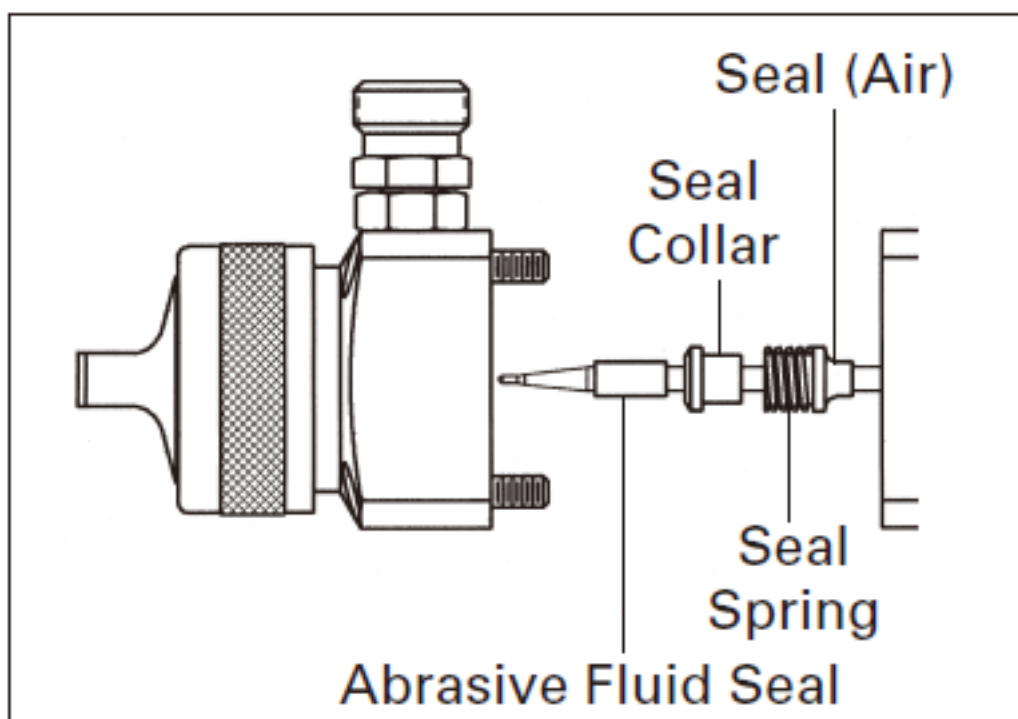

Torque Specifications		
Ref. No.	Torque Requirements	
	Inch or Ft. Lbs.	N-m
3	20-25 ft. lbs.	27.0 - 24.0
7	30-40 in. lbs.	3.4 - 4.5
6&9	12 ft. lbs.	16.3
21	220 in. lbs.	21.5 - 24.9
24	30 in. lbs.	3.4



SERVICE CHECK

Normal spray pattern









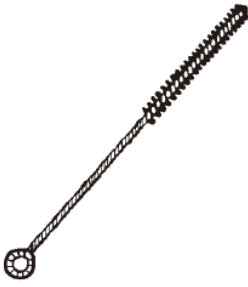

The proper combination of fluid pressure, fan and atomization air pressure, and fluid tip size should result in a pattern of this shape.

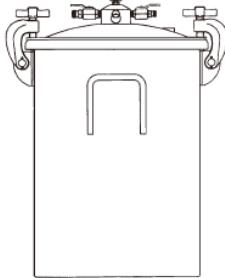
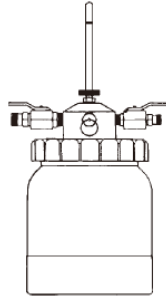
Proper gun adjustment will result in normal spray patterns, from round with the fan control valve (23) closed, to long and narrow with the valve open. Pattern width depends upon how much the valve is opened, the type of air cap used and fluid flow rate.

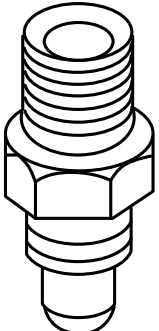
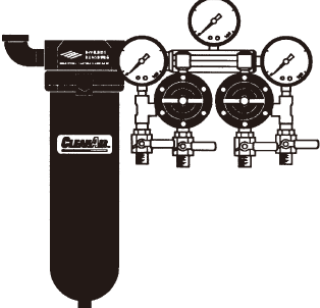
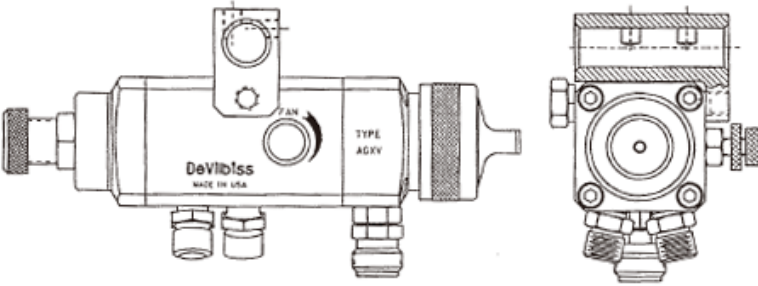
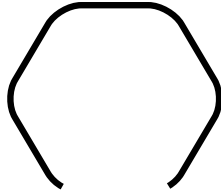
problem	Cause	Correction
Will not spray.	No pressure to gun. Piston stops moving. New air packing (20)	Check air and material lines. Check tightness of socket screws (7). Remove fluid needle (28) and lubricate with petroleum jelly and reassemble.
Improper spray pattern. 	A. Gun not adjusted properly. A, B. Material build up on the air cap or fluid tip. Note To determine where the material build up is, rotate the air cap 180° and test spray. If the pattern stays in the same position, the condition is caused by material build up on the fluid tip. If the pattern changes with air cap movement, the buildup is in the air cap. C. Wrong material or material too thick. D. Insufficient material or atomizing air pressure too high.	A. Re-adjust. See "Operation Section". A, B. Clean the air cap or fluid tip. See "Preventive Maintenance". C. Adjust material pressure or thin material. D. Increase material or reduce atomizing air pressure.
Jerky or fluttering spray 	1. Insufficient material in the tank or an obstruction in the line. 2. Gun material passage plugged. 3. Worn packings (11). 4. Loose or damaged Fluid Tip.	1. Fill tank or clear obstruction. 2. Clean. 3. Replace. 4. Tighten or replace.
Fluid leaking from needle Needle packings (11).	1. Needle packings (11) worn. 2. Rough or worn fluid needle shaft.	1. Replace. 2. Polish contact point where packings (11) makes contact with very fine emery cloth or replace tip (3) & needle (28).
Dripping from Fluid Tip.	1. Contamination (i.e. dried paint) in seating area of tip (3). 2. Worn or damaged fluid tip (3) or needle (28). 3. Piston springs (30) and/or (31) damaged or deformed.	1. Clean. 2. Replace. 3. Replace.
Air Leakage from Control Valve (23)	Worn seals.	Replace valve. (23).

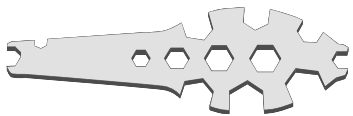
ACCESSORIES

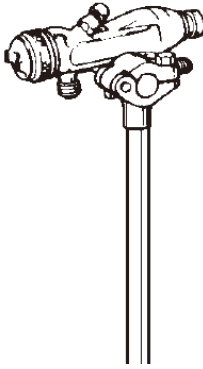
<p>42884-214-K5 3/8" 42884-215-K10 5/8" Cleaning Brushes</p>	<p>AGA-415 Universal Clamp</p>	<p>183GZ-5200 Hose/Gun Cleaner SolventSaver™</p>	<p>HD-503 (2 qt.) (2.1 Liters) Hose/Gun Cleaner SolventSaver™</p>	<p>SSL-10 Spray Gun Lube 2 oz. (60 ml) bottle</p>
 <p>These brushes are helpful in cleaning threads and recesses of gun body.</p>	 <p>Attaches to the gun stud (39), clamps onto a 19 mm (3/4") diameter rod and turns to any angles.</p>	 <p>2 gallon (7.6 liters) galvanized tank used to clean the inside of hose and material passages of the gun. Available in U.S. only.</p>	 <p>Used to clean the inside of hose and material passages of the gun.</p>	 <p>Use on air cap and retaining ring. Compatible with all paint materials, contains no silicone or petroleum distillates to contaminate paint. MSDS available upon request.</p>
<p>KK-4955 Fan Control Adapter Kit</p>	<p>HFRL-511 Filter-Regulator</p>	<p>KK-5046 Mounting Block Kit</p>		<p>JGA-156-K10 Spring Clips</p>
 <p>Used for adjusting pattern size from a remote air source.</p>	 <p>Use in the line between the source of air supply and the gun for the purpose of extracting dirt and entrained water and oil. Will also enable users to regulate and control atomization air pressure to the gun.</p>	 <p>Allows gun to be mounted on a 1/2" rod.</p>		 <p>Joins any single piece DeVilbiss air cap with latest version MBC- 368 or MSA-1 retaining ring. Helps prevent parts loss and provides easier assembly.</p>
<p>Millennium 3000 Twin Cartridge Paint Spray Respirator</p>	<p>WR-103 Wrench</p>	<p>29-3100 Scrubs® Hand Cleaner Towels</p>	<p>AGA-414 Extension Rod Assembly</p>	
 <p>NIOSH-Certified, for respiratory protection in atmospheres not immediately dangerous to life.</p>	 <p>Contains all necessary tip, hose and nut sizes used on or with gun.</p>	 <p>Scrubs® are a premoistened hand cleaner towel for painters. No water is needed.</p>	 <p>Rod Length : 16 inches (406mm) Rod Diameter : 3/4 inch (19mm) Clamp Diameter : 3/4 inch (19mm)</p>	

83C, 183G, 183S & 83Z Pressure Feed Tanks:

QMG/QMS Galvanized and Stainless Steel pressure feed tanks are intended for use as a pressure container to supply material at a constant preset pressure. 2, 5, 10 and 15 gallon models available.

KK-5017 Fluid Seal Kit

– For use with abrasive materials. Includes 1 brass seal collar and 3 polyethylene fluid seals.

DEVILBISS DIVISION

CFT Ransburg Japan KK

15-5, Fukuura 1-chome, Kanazawa-ku, Yokohama, Kanagawa Japan 〒236-0004
TEL : +81-45-785-6434 / FAX : +81-45-785-6517

website <http://www.carlisleleft.co.jp/>

©DEVILBISS is a registered trademark of Carlisle Fluid Technologies
©Jupiter is a registered trademark of CFT Ransburg Japan KK.



©2017 Carlisle Fluid Technologies.

2017-08- AGXV(HVLP)